



# VIQC Elementary School - Reverse Engineering Online Challenge



## Exploring the Inner Workings of the SONY DUALSHOCK3 Sixaxis Controller (Model # CECHZC2U)

Team 8310S - Crosswind EagleBots (Collierville, TN)

Sai Yerra

Vihaan Kapse

Emma Dai

# Table of Contents

<b>Summary .....</b>	<b>3</b>
<b>Parts List .....</b>	<b>5</b>
<b>Tools used for Deconstruction.....</b>	<b>5</b>
<b>Deconstructing Procedure .....</b>	<b>6</b>
<b>Component Analysis – Circuit Schematic .....</b>	<b>8</b>
<b>Component Analysis – Motherboard.....</b>	<b>9</b>
<b>Component Analysis – Vibrational Motor .....</b>	<b>11</b>
<b>Component Analysis – Lithium-Ion Battery .....</b>	<b>14</b>
<b>Component Analysis – Analog Joysticks .....</b>	<b>16</b>
<b>Software Used.....</b>	<b>18</b>
<b>Conclusion .....</b>	<b>18</b>
<b>Citation .....</b>	<b>19</b>

# Summary

While we were brainstorming to decide on the electronic device for our reverse engineering project, we realized that most of us kids play video games on consoles like PlayStation, Xbox, and Nintendo Switch. We use wireless controllers to play video games. We felt like exploring the various parts and the inner workings of the controller itself. We had a DualShock3 Sixaxis PlayStation wireless controller that wasn't being used anymore, so we chose this for our project.

The DualShock3 Sixaxis wireless controller was included with the PlayStation 3 when it launched in 2006. It was Sony's first official wireless controller and could detect motion with "six degrees of freedom," yet it did not have a rumble feature. The black DualShock 3 Sixaxis with the rumble feature was released in the United States on April 2, 2008, and in Europe on July 2, 2008. On October 30, 2008, the DualShock 3 became the standard controller packaged with PlayStation 3 console.

During disassembling, we came across the following major parts: front plate, back plate, lithium-ion battery, motherboard, vibrational motors, internal bracket, and various buttons used for operating the controller. The internal bracket kept all the parts in place. The lithium – ion battery powers the controller. The vibrational motors are basically normal electric motors, but when the motors turn, they wobble at semi-high speeds. This causes the controller to vibrate. The motherboard is a circuit board that has a processor to coordinate various operations from the controller to the console.

It was a great learning experience for all of us working on this reverse engineering project. It helped us learn specific tools that we needed to use to take apart a DualShock3 Sixaxis wireless controller. It also helped us understand more details about inner workings of the lithium-ion battery, motherboard, and vibrational motors. The next thing we learned was using computer software's such as Microsoft Word, Microsoft Paint, and Notepad++. Another thing we learned was how to do the proper research to know more details about the controller and various parts in it. Lastly, we learned how to work as a team and brainstorm ideas together. All these skills are very useful for building our Vex robot and the controller used for operating our robot.

## Parts List

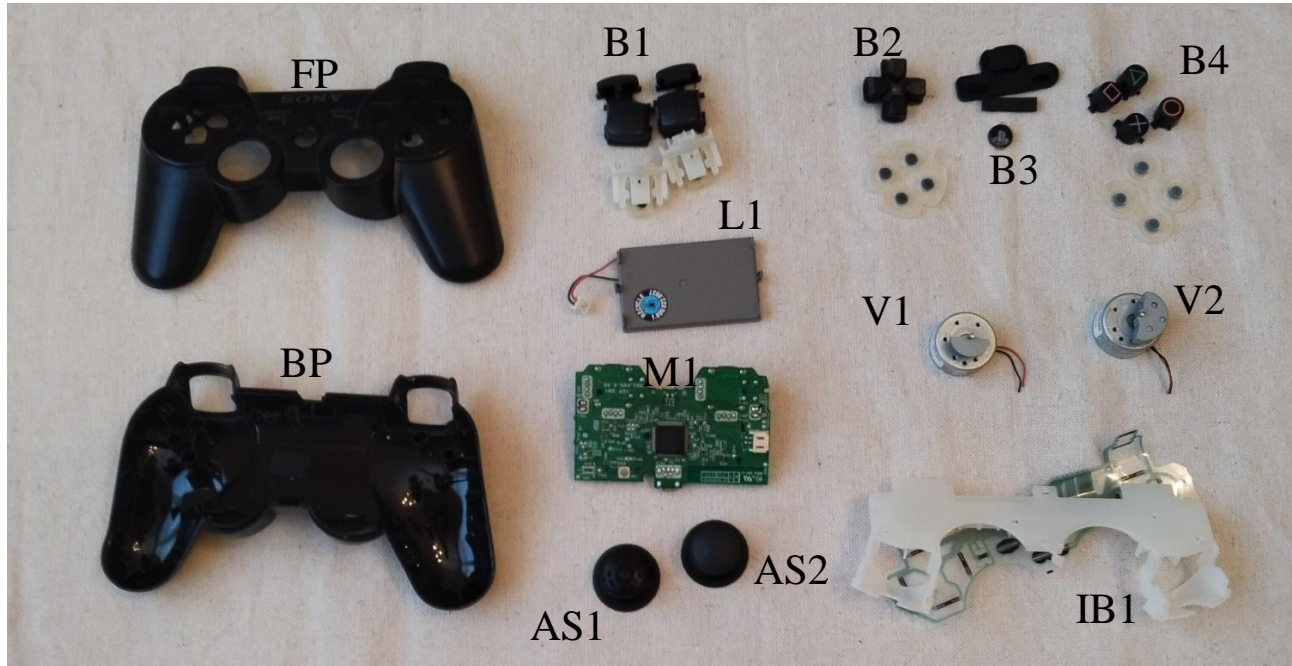

FP - Front Plate

BP - Back Plate

B1 - L1, L2, R1, R2 buttons

L1 - Lithium-ion Battery

M1 - Motherboard

AS1 - Analog Stick

AS2 - Analog Stick

B2 - Directional Button

B3 - PlayStation Button

B4 - Buttons

V1 - Vibration Motor

V2 - Vibration Motor

IB1 - Internal Bracket

## Tools used for Deconstruction

T1 - Safety Glasses

T2 - #0 Round and Flat Screwdrivers

T3 - Gloves

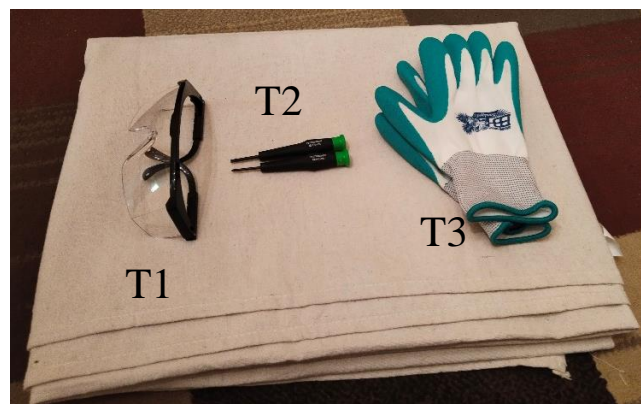

## Deconstructing Procedure

1. There were 5 screws holding the backplate. 1 screw was in the middle and the rest were on the sides. We used a zero sized screwdriver and took the screws out 1 by 1 and took off the back plate shown in the picture.



2. We unplugged the battery's connection from the motherboard and removed the battery to ensure that there is no electricity in the components for safety purposes.

3. There was 1 screw that attached the motherboard to the internal bracket. We removed the screw to separate the motherboard and the internal bracket and then we removed the analog sticks from the motherboard.



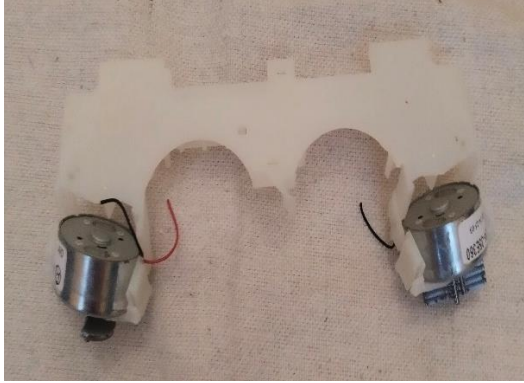

4. After we removed the motherboard, we removed the internal bracket by using a flat screwdriver. The way we used the screwdriver was by lifting it out of the front plate from all corners.

5. When we removed the internal bracket from the front plate, all the buttons fell off from the front plate because there was nothing holding it in place.



6. Lastly, we took out the vibration motors from the internal bracket grooves by pushing them out of the grooves with our thumb.

# Component Analysis – Circuit Schematic

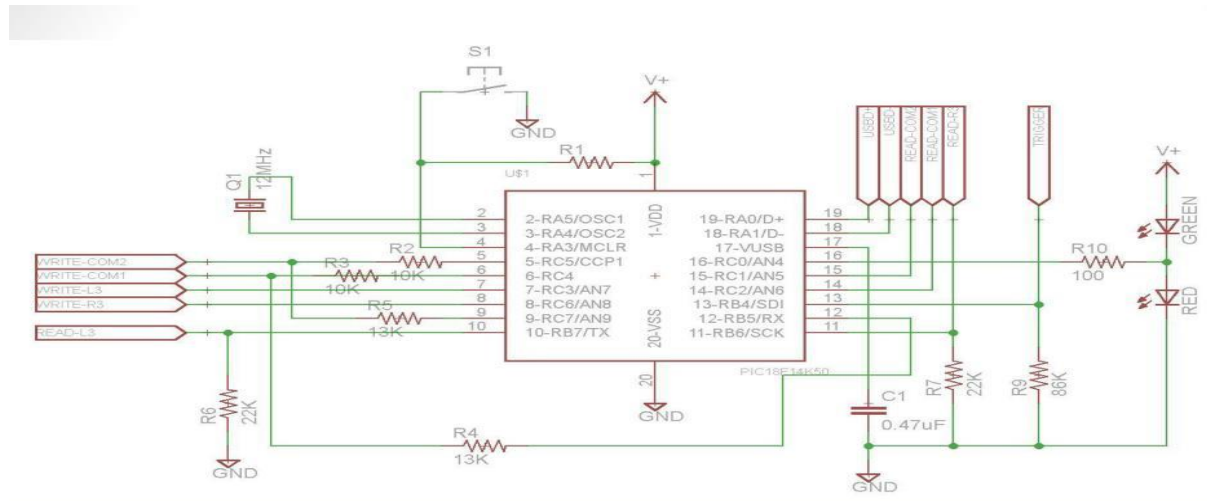

A circuit diagram is a wiring diagram, and it is a graphical representation of an electrical circuit. A pictorial circuit diagram uses simple images of components, while a schematic diagram shows the components and interconnections of the circuit using standardized symbolic representations.

A circuit diagram shows the actual electrical connections. It is a drawing meant to depict the physical arrangement of the wires and the components they connect. Circuit diagrams are used for the circuit design, construction, and maintenance of electrical and electronic equipment.







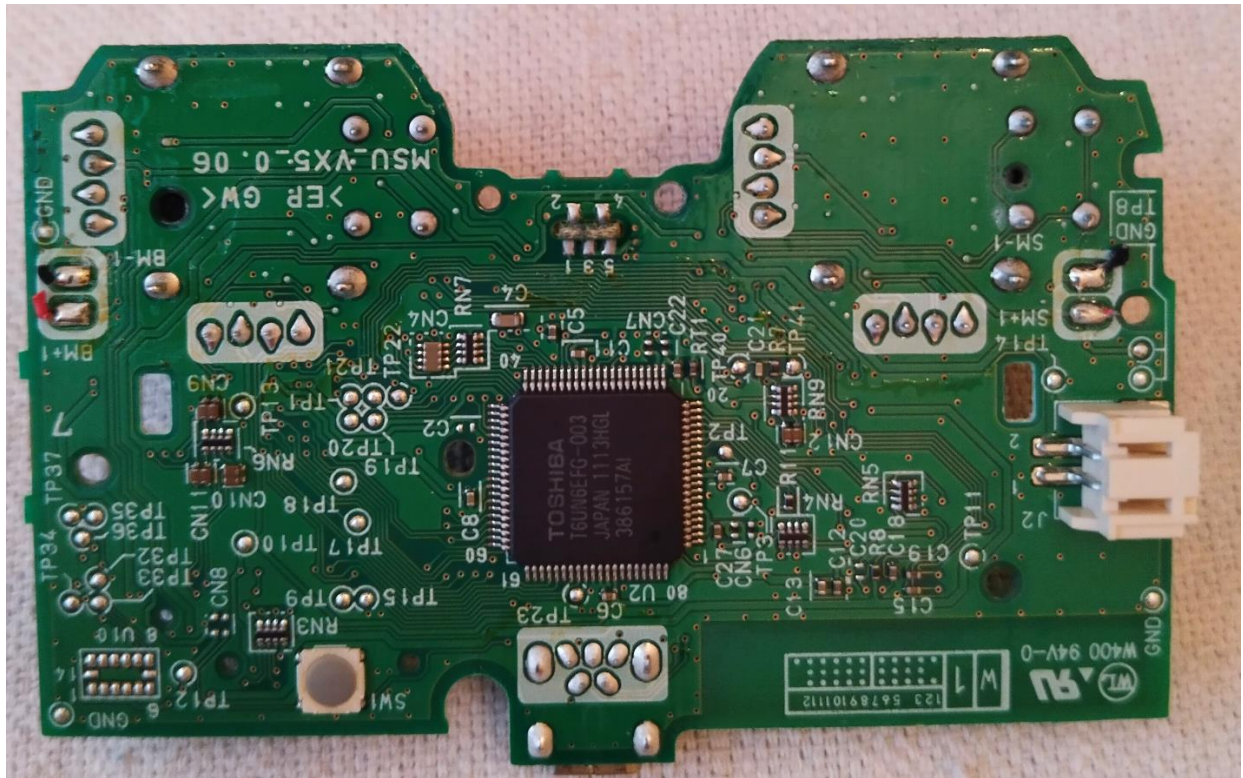











The schematic drawings are organized on the page from left to right and top to bottom in the same sequence as the flow of the main signal or power path.



# Component Analysis – Motherboard



## CIRCUIT ELEMENTS

Active Circuit Elements			Passive Circuit Elements		
Transistor			Resistor		
Diode			LDR		
LED			Thermistor		
Photodiode			Capacitor		
Integrated Circuit		-	Inductor		

The motherboard is the backbone that ties the controller's components together at one spot and allows them to talk to each other. Without it, none of the controller pieces, such as the CPU, GPU, or hard drive, could interact. Total motherboard functionality is necessary for a controller to work well.

The following common components are used in most printed circuit boards:

***Resistors*** - Resistors control the electric currents that pass through them, as well as the voltage in each component connected to them. Without resistors, other components may not be able to handle the voltage, and this may result in overloading.

***Transistors*** - Transistors are crucial to the printed circuit board assembly process due to their multi-functional nature. They are semiconductor devices that can both conduct and insulate and can act as switches and amplifiers. They are smaller in size, have a relatively longer life, and can operate at lower voltage supplies safely without a filament current. Transistors come in two types: bipolar junction transistor (BJT) and field effect transistors (FET).

***Capacitors*** - Capacitors are passive two-terminal electronic components. They act like rechargeable batteries – they can store electrical energy, and then transmit that energy again when needed.

***Inductors*** - Inductors are passive two-terminal electronic components that store energy in a magnetic field when an electric current passes through them. Inductors are used to block alternating currents while allowing direct currents to pass. They can be combined with capacitors to make tuned circuits, which are used in radio and TV receivers.

**Diodes** - Diodes are semiconductor components that act as one-way switches for currents. They allow currents to pass easily in one direction but restricts currents from flowing in the opposite direction.

**Microprocessor** - The microprocessor, also known as the Central Processing Unit (CPU), is the brain of controller. Dualshark3 Sixaxis PlayStation controller that was used in our project uses Toshiba model # T6UN6EFG-003 microprocessor.

## Component Analysis – Vibrational Motor

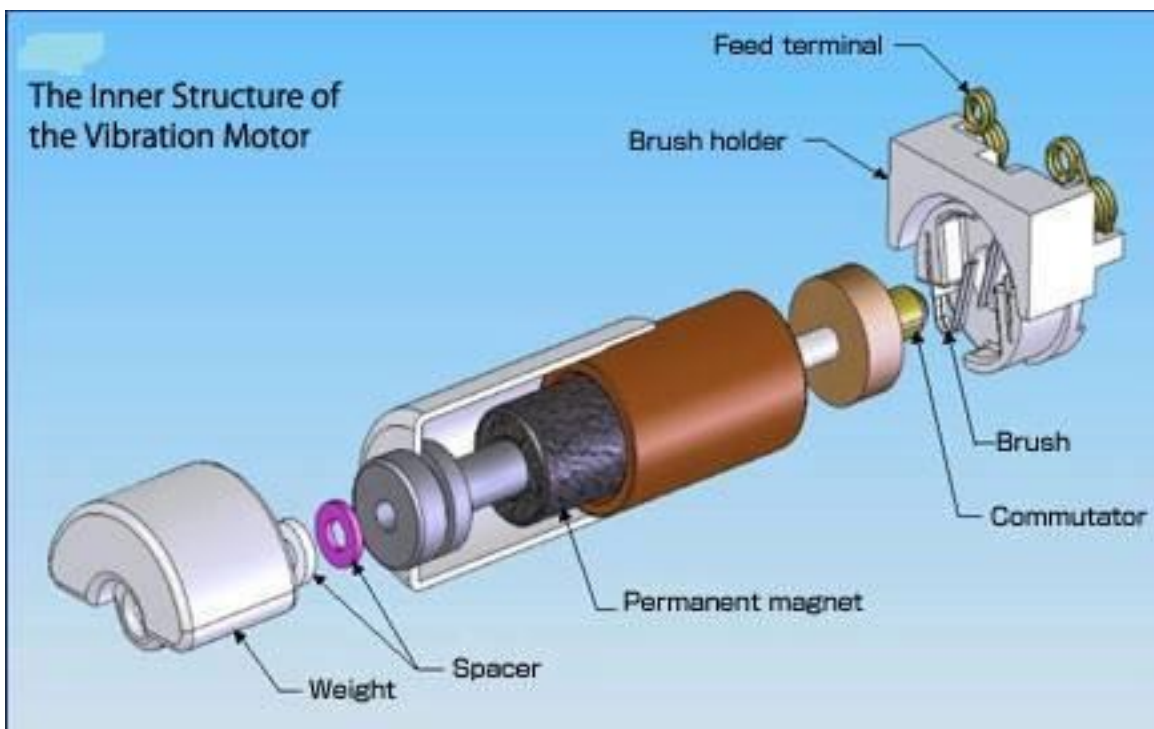

The Vibrational motors that are contained within the handle of the PlayStation controller, are not that complicated to understand when we are looking at them from a qualitative point of view. Basically, they are just regular electric motors, that have non-evenly distributed weights mounted upon them. Thus, when the motors turn, they will wobble; and when this is done at semi-high speeds, they get that legendary vibratory presence.

### DC Motor Magnets

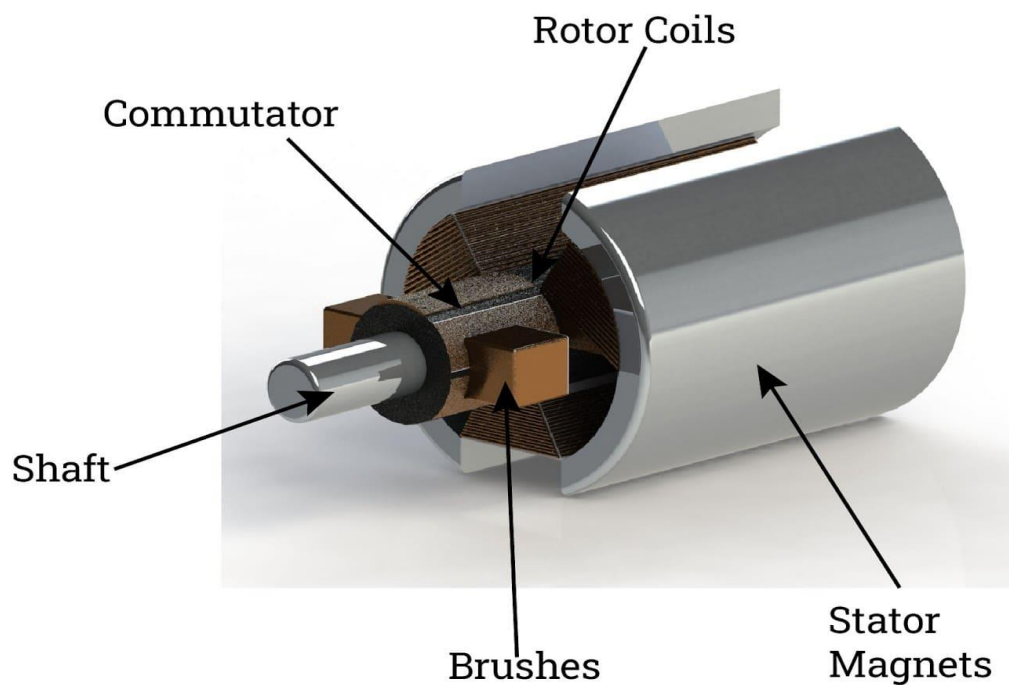

[IQSdirectory.com](http://IQSdirectory.com)

A simple motor has six parts:

- Stator
- Rotor
- Commutator
- Brushes
- Shaft

***Stator*** - The stator is the unmoving main body of the motor, and it provides support and protection for the motor. The stator provides a rotating magnetic field that drives the armature or rotor. It is the static part of the motor that houses the field windings and receives the electrical supply through its terminals.

***Rotor*** - The rotor or armature is made of multiple disks that are insulated from each other by laminated sheets. The multiple disks prevent the creation of a large eddy current. They are a necessary part of the motor's operation. For greater motor efficiency, the disks of the rotor are made as small as possible. The rotor is the dynamic part of the motor that is used to create the mechanical revolutions.

***Commutator*** - The commutator is made of small copper plates that are mounted on the shaft and rotate as the shaft rotates. The rotation of the rotor causes the poles of the power supply to the coils to change. Each coil is connected to two commutator plates, which are electrically isolated from each other but connected by the coils. With positive and negative terminals connected to two commutator plates, current easily flows and an electromagnetic field is generated.

**Brushes** - The brushes of a DC motor provide the coils with power and are metal pieces that act like springs. On one side, they have a conductive material made of carbon. On the other side, they have a pin where the power supply is applied to the motor.

**Shaft** - The windings and the commutator rotate the shaft, which is at the center of the motor and made of a hardened metal, usually steel, to withstand the loads of the application. The commutator bars are attached to the plate that is affixed to the shaft by plastic molding. The torque that is produced by the winding is transferred to the shaft supported by the stator. The shaft protrudes through the stator and connects the motor to the application.

## Component Analysis – Lithium-Ion Battery



### Lithium-ion rechargeable battery Charge mechanism

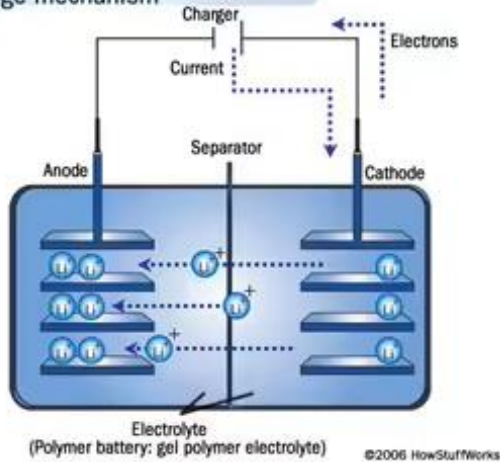

### Lithium-ion rechargeable battery Discharge mechanism

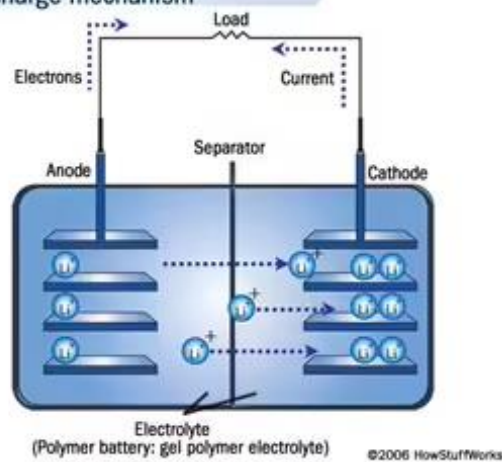

Lithium-ion batteries are incredibly popular these days. We can find them in laptops, cell phones, controllers, electric vehicles and many other electronic devices. They're so common because they're some of the most energetic rechargeable batteries available.

An outer case made of metal. The use of metal is important because the battery is pressurized. This metal case has pressure-sensitive vent hole. If the battery ever gets so hot that it risks exploding from over-pressure, this vent will release the extra pressure. The vent is a safety measure.

This metal case holds a long spiral comprising three thin sheets pressed together:

- A Positive electrode
- A Negative electrode
- A Separator

Inside the case these sheets are submerged in an organic solvent that acts as the electrolyte. Ether is one common solvent

The separator is a very thin sheet of microperforated plastic. It separates the positive and negative electrodes while allowing ions to pass through.

The positive electrode is made of Lithium cobalt oxide, or  $\text{LiCoO}_2$ . The negative electrode is made of carbon. When the battery charges, ions of lithium move through the electrolyte from the positive electrode to the negative electrode and attach to the carbon. During discharge, the lithium ions move back to the  $\text{LiCoO}_2$  from the carbon.

## Component Analysis – Analog Joysticks

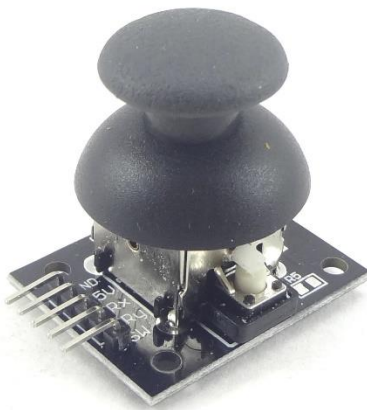





The Analog Joystick, sometimes called a control stick or thumb stick, is an input device for a controller that is used for two-dimensional input. One of the sticks is used for the vertical movement (Y-axis) and other for the horizontal movement (X-axis).

Joysticks fall into two categories, analog and digital. Digital joysticks allow the user only to input four directions (i.e., up, down, left, and right) or eight directions (i.e., up, down, left, right, and 4 diagonals). Analog joysticks allow inputs in all directions and map the full range of motion of the joystick in its given position. Analog joysticks allow for slight movement to be detected rather than an “on and off” type of response that digital joysticks have.

## Software Used

- *Microsoft word* – Documenting the report
- *Paint* – Edit and Crop pictures
- *Notepad ++* - Notes from group discussion
- *Google Chrome browser* – Online research

## Conclusion

In conclusion, it was a great learning and fun experience for all of us working on this project. We learned to work as a team. This experience also helped us become better friends, and a better team.



# Citation

- [https://ifixit-guide-pdfs.s3.amazonaws.com/pdf/ifixit/guide\\_3254\\_en.pdf](https://ifixit-guide-pdfs.s3.amazonaws.com/pdf/ifixit/guide_3254_en.pdf)
- [https://www.youtube.com/watch?v=A\\_frP8nMERI](https://www.youtube.com/watch?v=A_frP8nMERI)
- <https://www.youtube.com/watch?v=MVTkwSkZZAY>
- <https://www.youtube.com/watch?v=ETGcv7Ou7zQ>
- <https://www.youtube.com/watch?v=VmtVK4mjQew>
- [https://www.youtube.com/watch?v=7p\\_eQ6S7JPo](https://www.youtube.com/watch?v=7p_eQ6S7JPo)
- <https://manuals.playstation.net/document/en/ps3/current/index.html>
- [https://controller.dl.playstation.net/controller/lang/en/DS\\_partnames.html](https://controller.dl.playstation.net/controller/lang/en/DS_partnames.html)
- <https://www.ign.com/articles/the-evolution-of-the-playstation-controller>
- <https://en.wikipedia.org/wiki/Sixaxis>
- [https://en.wikipedia.org/wiki/Circuit\\_diagram](https://en.wikipedia.org/wiki/Circuit_diagram)
- <https://www.hp.com/us-en/shop/tech-takes/what-does-a-motherboard-do>
- <https://www.permatechelectronics.com/understanding-5-electronic-components-used-in-circuit-boards/blog.html>
- [https://en.wikipedia.org/wiki/Rotor\\_\(electric\)](https://en.wikipedia.org/wiki/Rotor_(electric))
- <https://electronics.howstuffworks.com/motor.htm#pt3>
- <https://www.iqsdirectory.com/articles/electric-motor/dc-motors.html>
- <https://www.egr.msu.edu/classes/ece480/capstone/spring13/group05/downloads/Application%20Note-yangyi.pdf>
- <https://electronics.howstuffworks.com/everyday-tech/lithium-ion-battery.htm>